



Product Data

50GL Single-Package Electric Cooling Units

with Puron® (R-410A) Refrigerant

2 to 5 Nominal Tons

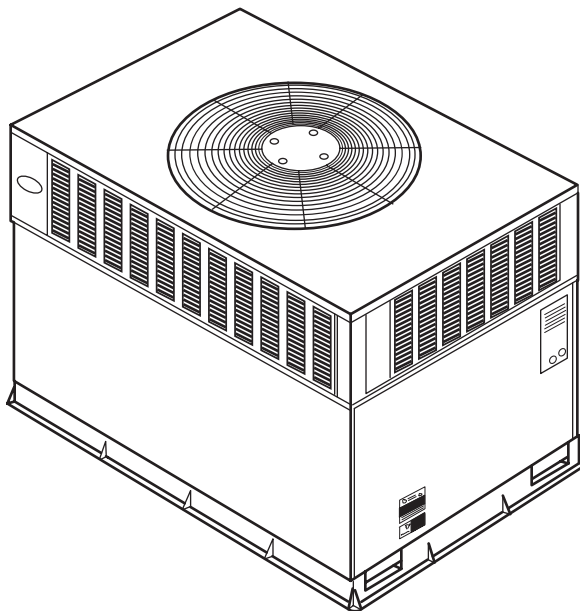

UNIT 50GL

Single-Package Products with Energy-Saving Features and Puron® refrigerant.

- Low Sound Levels
- 12 SEER
- Variable Speed Blower Option

Features/Benefits

One-piece cooling unit with optional electric heater, low installation cost, dependable performance and easy maintenance.

Efficient operation

High-efficiency design with a SEER (Seasonal Energy Efficiency Ratio) of 12.0.

Puron® Environmentally Sound Refrigerant is Carrier's unique refrigerant designed to help protect the environment. Puron is an HFC refrigerant which does not contain chlorine that can harm the ozone layer. The most important advantage of Puron refrigerant is that it has not been banned in future air conditioning systems as the traditional refrigerant R-22 has been. Puron refrigerant is in service in thousands of systems proving highly reliable, environmentally sound performance.

ComfortHeat™ Technology featuring Variable Speed Blower motors provides better comfort and energy efficiency. You can expect up to 30 times better dehumidification; a SEER boost of up to 12.7; economical constant fan for less than \$30 a year, which provides improved indoor air quality and more even temperatures from room to room; and reduced indoor noise due to lower air velocity. In addition, you'll realize improved installation flexibility with 3 different airflow choices for best overall comfort.

Easy Installation

Factory-assembled package is a compact, fully self-contained, electric

cooling unit that is pre-wired, pre-piped, and pre-charged for minimum installation expense. 50GL units are available in a variety of standard cooling sizes with voltage options to meet residential and light commercial requirements. Units are light weight, and install easily on a rooftop or at ground-level. The hightech, composite base pan eliminates rust problems associated with ground level applications.

Durable, dependable components

Scroll Compressors are designed for high efficiency. Each compressor is hermetically sealed against contamination to help promote longer life and dependable operation. Vibration isolation provides quiet operation. Compressors have internal high-pressure and overcurrent protection.

Convertible duct configuration

Unit is designed for easy use in either downflow or horizontal applications. Each unit is easily converted from horizontal to downflow.

Direct-drive multi-speed, PSC (permanent split capacitor) blower motor is standard on all 50GL models.

Direct-drive, PSC condenser-fan motors are designed to help reduce energy consumption and provide for cooling operation down to 40°F outdoor temperature. Motormaster® II low ambient kit is available as a field-installed accessory.

Corporate thermostats include the Time Guard® II anti-short cycle

protection circuitry. If a non-Corporate thermostat without anti-short cycle protection, is used the Time Guard II field installed anti-short cycle kit is recommended.

Refrigerant system is designed to provide dependability. Liquid refrigerant filter driers are used to promote clean, unrestricted operation. Each unit leaves the factory with a full Puron® refrigerant charge. Refrigerant service connections are standard on the suction and discharge lines for checking operating pressures.

Evaporator and condenser coils are computer-designed for optimum heat transfer and cooling efficiency. The evaporator coil is fabricated from copper tube and aluminum fins and is located inside the unit for protection against damage. The condenser coil is internally mounted on the top tier of the unit. Copper fin coils and pre-coated fin coils are available from the factory by special order. These coils are recommended in applications where aluminum fins are likely to be damaged due to corrosion. They are ideal for seacoast applications.

High and Low Pressure Switches give added safety and reliability to the compressor.

Low sound ratings ensure a quiet indoor and outdoor environment with sound ratings as low as 72 dB. (See page 3.)

Easy to service cabinets provide easy single-panel accessibility to serviceable components during maintenance and installation. The basepan with integrated drain pan provides easy

ground level installation with or without a mounting pad. Convenient handholds are provided to manipulate the unit on the jobsite. A nesting feature ensures a positive basepan to roof curb seal when the unit is roof mounted. A convenient 3/4-in. wide perimeter flange makes frame mounting on a rooftop easy.

Louvered Grille provides hail and vandalism protection for the coil.

Downflow operation is easily provided in the field to allow vertical ductwork connections. The basepan utilizes knockout style seals on the bottom openings to ensure a positive seal in the horizontal airflow mode.

Cabinets are constructed of heavy-duty, phosphated, zinc-coated prepainted steel capable of withstanding 500 hours of salt spray. Interior surfaces of the evaporator and electric heater compartments are insulated with cleanable semi-rigid insulation board, which keeps the conditioned air from being affected by the outdoor ambient temperature and provides improved indoor air quality. (Conforms to American Society of Heating, Refrigeration and Air Conditioning Engineers No. 62P.) The sloped drain pan minimizes standing water in the drain, which is provided with an external drain.

Standard metal duct covers with insulation come with the unit and cover the horizontal duct openings. These can be left in place if the unit is converted to downflow.

Table of contents

	Page
Features/Benefits	1,2
Model Number Nomenclature	3
ARI Capacities	3
Physical Data	4
Options and Accessories	5,6
Base Unit Dimensions	7,8
Accessory Dimensions	9
Selection Procedure	10
Performance Data	11-16
Typical Piping and Wiring	17
Application Data	18
Electrical Data	19, 20
Typical Wiring Schematics	21, 24
Controls	25
Guide Specifications	26, 27

Model number nomenclature

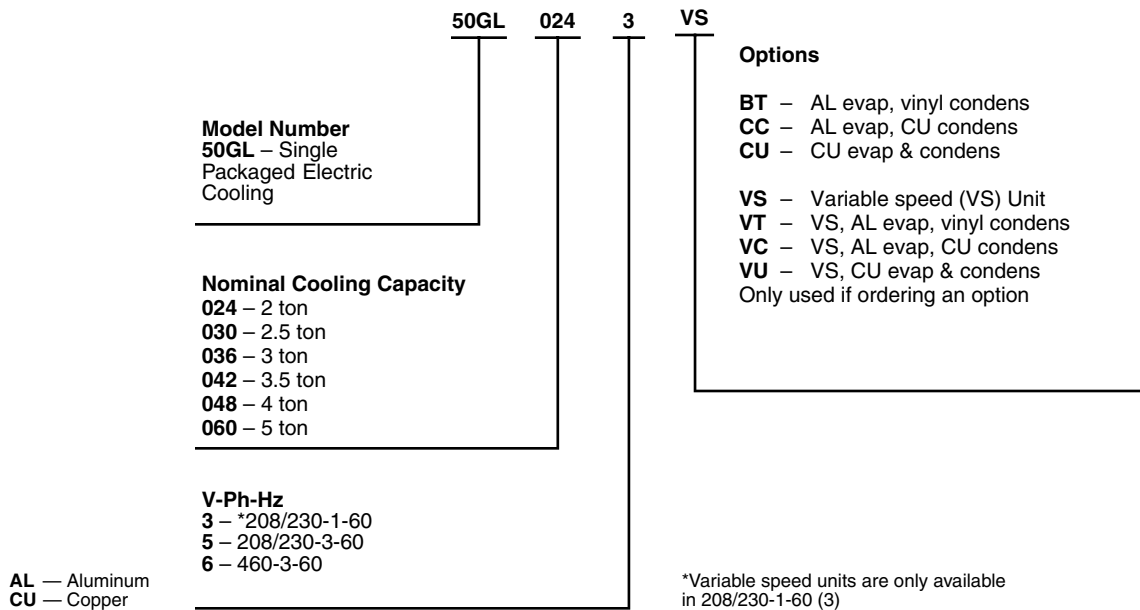

ARI* capacities

COOLING CAPACITIES AND EFFICIENCIES

UNIT 50GL	NOMINAL TONS	STANDARD CFM	NET COOLING CAPACITIES (Btuh)	SEER†	SOUND RATINGS‡ (dB)
024	2	800	24,000	12.0	72
030	2-1/2	1000	29,000	12.0	72
036	3	1200	35,000	12.0	72
042	3-1/2	1400	41,000	12.0	73
048	4	1600	48,000	12.0	78
060	5	1750	59,000	12.0	76

LEGEND

- dB** — Sound Levels (decibels)
- db** — Dry Bulb
- SEER** — Seasonal Energy Efficiency Ratio
- wb** — Wet Bulb

* Air Conditioning & Refrigeration Institute.

† Rated in accordance with U.S. Government DOE Department of Energy) test procedures and/or ARI Standard 210/240-94.

‡ Tested in accordance with ARI Standard 270-95 (not listed in ARI).

NOTES:

1. Ratings are net values, reflecting the effects of circulating fan heat. Ratings are based on:
Cooling Standard: 80°F db, 67°F wb indoor entering-air temperature and 95°F db outdoor entering-air temperature.
2. Before purchasing this appliance, read important energy cost and efficiency information available from your retailer.

50GL WITH ICM FIOP RATINGS

UNIT 50GL	"A"*** CAPACITY	"A"*** EER	SEER
024	24,000	10.7	12.7
030	29,000	10.7	12.7
036	35,000	10.6	12.5
042	41,000	10.7	12.5
048	48,000	10.5	12.3
060	59,000	10.4	12.3

***"A" Capacity- 80°F indoor db/67°F indoor wb & 95°F outdoor db.

OUTDOOR SOUND: ONE-THIRD OCTAVE BAND DATA—DECIBELS

UNIT Frequency (Hz)	50GL					
	024	030	036	042	048	060
63	44.8	48.0	50.0	49.1	51.4	53.7
125	60.4	58.2	60.4	63.9	65.2	62.6
250	58.3	59.2	61.6	65.2	69.7	65.9
500	64.8	65.8	66.9	67.9	72.7	70.6
1000	66.9	67.7	67.8	66.7	72.9	71.6
2000	64.3	64.8	64.6	63.8	69.8	68.2
4000	59.8	61.8	60.7	60.2	65.8	65.8
8000	51.8	53.6	52.8	50.7	57.9	58.3

Physical data

UNIT SIZE 50GL	024	030	036	042	048	060
NOMINAL CAPACITY (ton)	2	2-1/2	3	3-1/2	4	5
OPERATING WEIGHT (lb)	270	291	299	321	326	399
COMPRESSOR	Scroll					
REFRIGERANT (R-410A) Quantity (lb)	5.0	5.5	6.9	9.0	9.5	10.0
REFRIGERANT METERING DEVICE Orifice ID (in.)	.057	.057	.065	.070	.073	.086
CONDENSER COIL Rows—Fins/in. Face Area (sq ft)	1—17 9.1	1—17 12.7	2—17 9.1	2—17 12.3	2—17 12.3	2—17 16.4
CONDENSER FAN Nominal Cfm Diameter (in.) Motor Hp (Rpm)	2350 22 1/8 (825)	2350 22 1/8 (825)	2350 22 1/8 (825)	2350 22 1/8 (825)	3300 22 1/4 (1100)	3300 22 1/4 (1100)
EVAPORATOR COIL Rows—Fins/in. Face Area (sq ft)	3—15 3.7	3—15 3.7	3—15 3.7	3—15 4.7	4—15 4.7	4—15 4.7
STANDARD EVAPORATOR BLOWER Nominal Airflow (Cfm) Size (in.) Motor (Hp)	800 10 x 10 1/4	1000 10 x 10 1/4	1200 10 x 10 1/2	1400 11 x 10 3/4	1600 11 x 10 3/4	1750 11 x 10 1.0
EVAPORATOR BLOWER ICM FIOP ONLY Nominal Airflow (Cfm) Size (in.) Motor (Hp)	800 10 x 10 1/2	1000 10 x 10 1/2	1200 10 x 10 3/4	1400 11 x 10 3/4	1600 11 x 10 3/4	1750 11 x 10 1.0
HIGH-PRESSURE SWITCH (psig) Cutout Reset (Auto.)	610 ± 15 420 ± 25					
LOSS-OF-CHARGE/LOW-PRESSURE SWITCH (Liquid Line) (psig) Cutout Reset (Auto.)	20 ± 5 45 ± 10					
RETURN-AIR FILTERS (in.)* Throwaway	20 x 20 x 1	20 x 20 x 1	20 x 24 x 1	24 x 30 x 1	24 x 30 x 1	24 x 30 x 1

* Required filter sizes shown are based on the larger of the ARI (Air Conditioning & Refrigeration Institute) rated cooling airflow or the heating airflow velocity of 300 ft/min for throwaway type or 450 ft/min for high-capacity type. Air filter pressure drop for non-standard filters must not exceed 0.08 in. wg.



ECONOMIZER

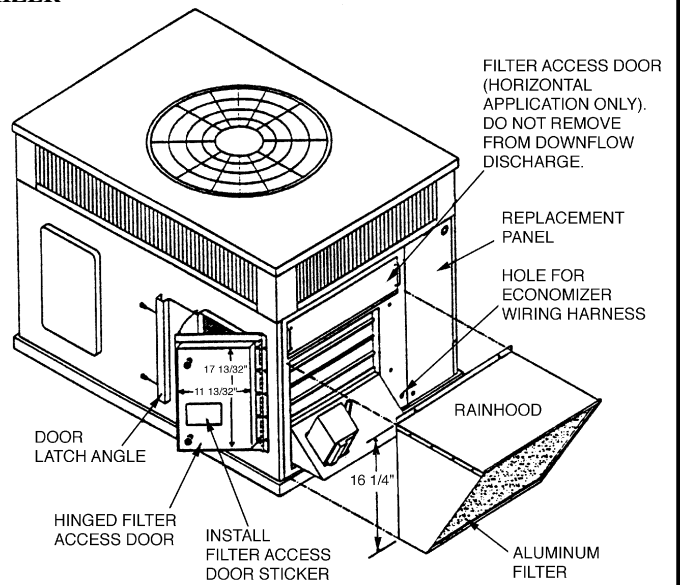
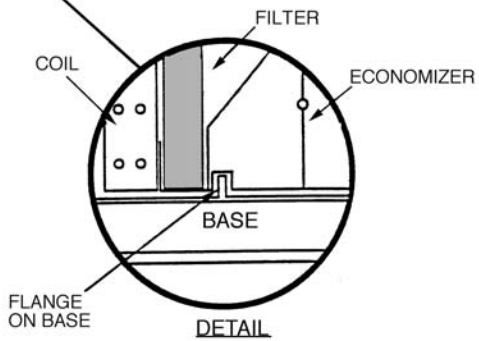
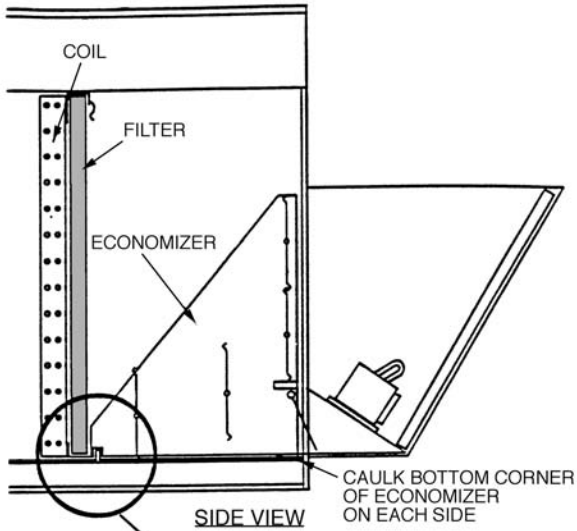

FILTER RACK

BEND FLANGE AT 90°-SCREW TO DIVIDER WITH 1-IN. SCREW

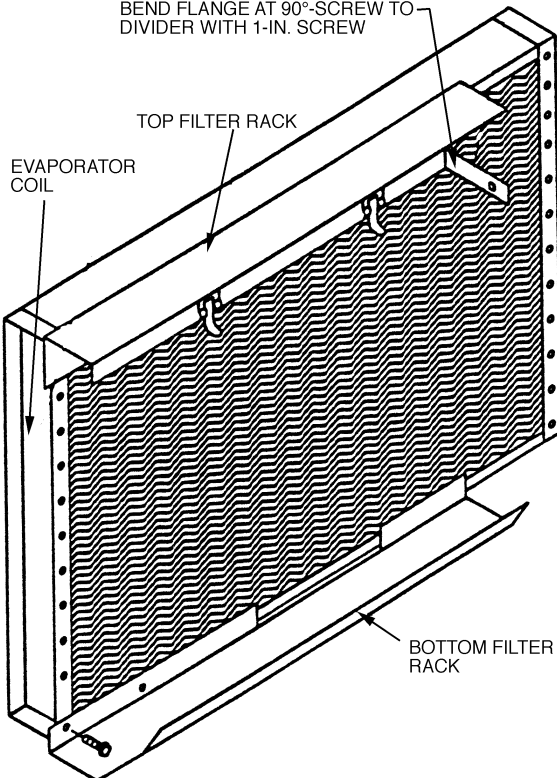

MANUAL OUTSIDE AIR DAMPER

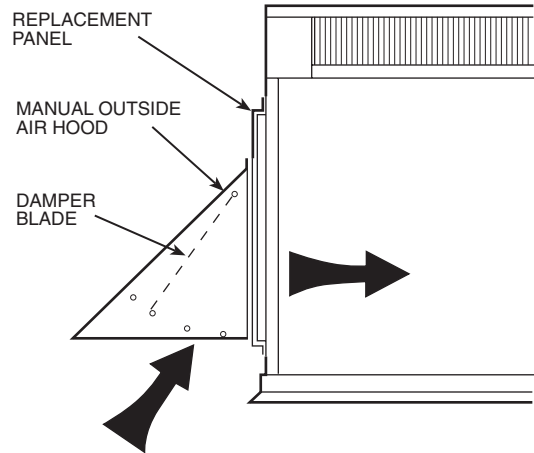

Base unit dimensions—50GL024-036

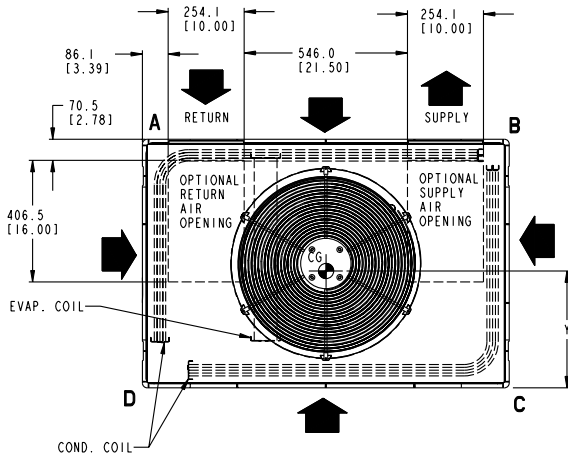

TOP VIEW

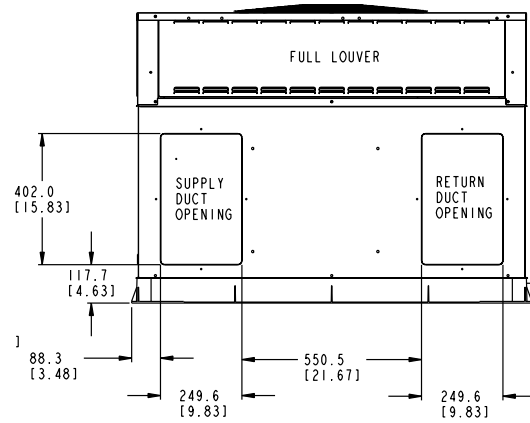

REAR VIEW

REQUIRED CLEARANCES TO COMBUSTIBLE MATL.

	MILLIMETERS [IN]
TOP OF UNIT	355.6 [14.00]
DUCT SIDE OF UNIT	50.8 [2.00]
SIDE OPPOSITE DUCTS	355.6 [14.00]
BOTTOM OF UNIT	12.7 [0.50]
ELECTRIC HEAT PANEL	914.4 [36.00]

NEC. REQUIRED CLEARANCES.

	MILLIMETERS [IN]
BETWEEN UNITS, POWER ENTRY SIDE	1066.8 [42.00]
UNIT AND UNGROUNDED SURFACES, POWER ENTRY SIDE	914.0 [36.00]
UNIT AND BLOCK OR CONCRETE WALLS AND OTHER GROUNDED SURFACES, POWER ENTRY SIDE	1066.8 [42.00]

REQUIRED CLEARANCE FOR OPERATION AND SERVICING

	MILLIMETERS [IN]
EVAP. COIL ACCESS SIDE	914.0 [36.00]
POWER ENTRY SIDE (EXCEPT FOR NEC REQUIREMENTS)	914.0 [36.00]
UNIT TOP	914.0 [36.00]
SIDE OPPOSITE DUCTS	914.0 [36.00]
DUCT PANEL	304.8 [12.00]

*MINIMUM DISTANCES: IF UNIT IS PLACED LESS THAN 304.8 [12.00] FROM WALL SYSTEM, THEN SYSTEM PERFORMANCE MAYBE COMPROMISED.

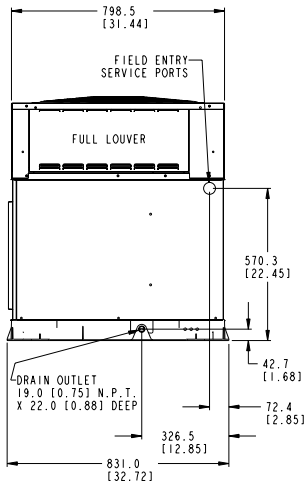

LEFT SIDE VIEW

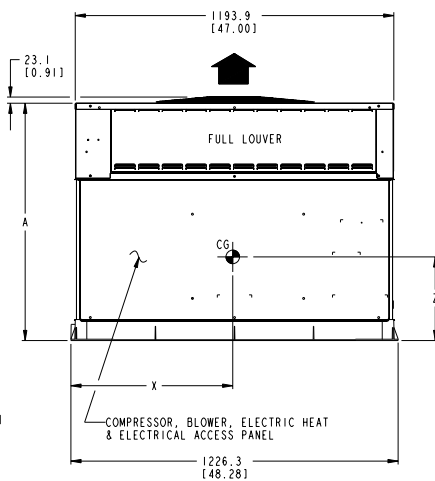

FRONT VIEW

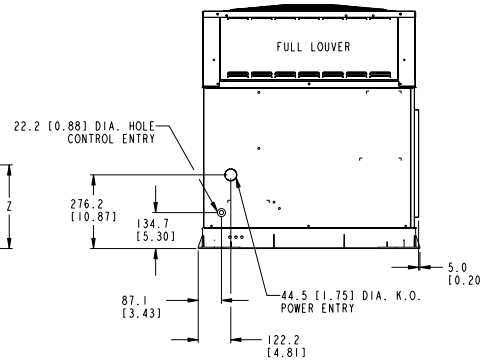

RIGHT SIDE VIEW

UNIT	ELECTRICAL CHARACTERISTICS	UNIT WEIGHT		UNIT HEIGHT in. [mm] "A"	CENTER OF GRAVITY in. [mm]		
		lb	kg		X	Y	Z
50GL024	208/230-1-60	270	122.5	37.02 [940.3]	18.5 [469.9]	14.5 [368.3]	16.0 [406.4]
50GL030	208/230-1-60, 208/230-3-60	291	132.0	39.02 [991.1]	19.5 [495.3]	15.5 [393.7]	17.6 [447.0]
50GL036	208/230-1-60, 208/230-3-60, 460-3-60	299	135.6	35.02 [889.5]	19.5 [495.3]	15.3 [387.4]	16.5 [419.1]

50GL 024-036 Dimensions

Performance data-Standard PSC Indoor Motor

COOLING CAPACITIES

50GL024 COOLING PERFORMANCE TABLE

Temp (F) Outdoor Air Entering Condenser		Evaporator Air—CFM/BF								
		600/0.08			800/0.10			1000/0.12		
		Evaporator Air — Ewb (F)								
		62	67	72	62	67	72	62	67	72
75	TC	23.7	26.0	28.1	24.7	26.9	28.7	25.2	26.9	28.7
	SHC	19.6	16.8	13.9	22.3	18.6	14.5	24.4	19.7	14.9
	KW	1.74	1.76	1.78	1.88	1.90	1.91	2.04	2.09	2.11
85	TC	22.4	25.0	27.2	23.6	25.8	27.7	24.1	25.9	27.5
	SHC	18.9	16.3	13.4	21.8	18.2	14.2	24.1	19.4	14.6
	KW	1.91	1.96	1.97	2.07	2.09	2.11	2.22	2.29	2.30
95	TC	21.2	23.7	26.2	22.3	24.0	26.7	23.0	24.7	26.4
	SHC	18.4	15.8	13.0	21.1	17.3	13.8	23.0	19.0	14.1
	KW	2.11	2.17	2.21	2.25	2.25	2.35	2.40	2.52	2.52
105	TC	19.1	21.5	23.8	20.1	22.3	24.2	21.0	22.3	24.1
	SHC	17.1	14.6	12.0	19.5	16.4	12.8	21.0	17.8	13.1
	KW	2.37	2.45	2.47	2.52	2.61	2.61	2.68	2.81	2.81
115	TC	16.9	19.3	21.8	18.2	20.0	22.3	19.2	20.1	22.1
	SHC	15.9	13.5	11.1	18.2	15.4	11.9	19.2	16.8	12.6
	KW	2.73	2.82	2.89	2.88	3.01	3.02	3.07	3.21	3.23
125	TC	14.7	16.8	19.2	16.1	17.4	19.6	16.9	17.5	19.4
	SHC	14.7	12.5	10.2	16.1	14.2	11.1	16.9	15.7	11.6
	KW	3.16	3.28	3.38	3.34	3.46	3.51	3.54	3.68	3.72

50GL030 COOLING PERFORMANCE TABLE

Temp (F) Outdoor Air Entering Condenser		Evaporator Air—CFM/BF								
		750/0.08			1000/0.11			1250/0.15		
		Evaporator Air — Ewb (F)								
		62	67	72	62	67	72	62	67	72
75	TC	29.0	32.2	34.3	30.4	32.8	34.6	31.1	32.6	34.2
	SHC	25.2	21.5	17.2	29.0	23.5	18.0	31.1	24.7	18.1
	KW	2.11	2.14	2.15	2.28	2.32	2.33	2.46	2.58	2.59
85	TC	27.5	30.7	33.3	28.7	31.7	33.4	29.8	31.5	33.3
	SHC	24.5	20.9	16.8	28.1	23.3	17.6	29.8	24.4	18.0
	KW	2.34	2.38	2.44	2.52	2.60	2.62	2.68	2.87	2.84
95	TC	25.9	29.4	31.9	27.5	29.0	32.3	28.5	29.8	31.9
	SHC	23.7	20.4	16.3	27.5	21.9	17.2	28.5	24.3	17.7
	KW	2.58	2.65	2.67	2.78	2.75	2.85	2.95	3.09	3.12
105	TC	23.3	26.2	29.1	24.8	27.0	29.4	25.9	27.0	29.1
	SHC	22.0	18.7	15.1	24.8	21.1	16.0	25.9	22.9	16.4
	KW	2.90	3.00	3.01	3.07	3.19	3.20	3.31	3.43	3.47
115	TC	21.5	24.4	26.9	23.1	24.9	27.5	24.2	24.8	26.8
	SHC	21.2	17.9	14.2	23.1	20.2	15.2	24.2	22.0	15.7
	KW	3.14	3.28	3.33	3.39	3.49	3.48	3.62	3.74	3.79
125	TC	19.7	22.2	24.7	21.4	22.7	24.8	22.3	22.5	24.6
	SHC	19.7	16.8	13.4	21.4	19.2	14.3	22.3	21.0	14.8
	KW	3.55	3.69	3.70	3.78	3.86	3.89	4.00	4.10	4.10

See Legend and Notes on page 13.

Performance data (cont)

ECONOMIZER 1-in. FILTER PRESSURE DROP (in. wg)

UNIT50GL	PRESSURE DROP
024-036	0.20
042-060	0.25

MULTIPLICATION FACTORS

HEATER kW RATING	VOLTAGE DISTRIBUTION	MULTIPLICATION FACTOR
240	200	.69
	208	.75
	230	.92
	240	1.00
480	440	.84
	460	.92
	480	1.00

Example: 15.0 kW (at 240v) heater on 208 v
 = 15.0 (.75 mult factor)
 = 11.25 capacity at 208 v

FILTER PRESSURE DROP (In. wg)

FILTER SIZE	CFM																		
	500	600	700	800	900	1000	1100	1200	1300	1400	1500	1600	1700	1800	1900	2000	2100	2200	2300
20 X 20 X 1	0.05	0.07	0.08	0.10	0.12	0.13	0.14	0.15	—	—	—	—	—	—	—	—	—	—	—
20 X 24 X 1	—	—	—	—	0.09	0.10	0.11	0.13	0.14	0.15	0.16	—	—	—	—	—	—	—	—
24 X 30 X 1	—	—	—	—	—	—	—	0.07	0.08	0.09	0.10	0.11	0.12	0.13	0.14	0.15	0.16	0.17	0.18

ELECTRIC HEAT PRESSURE DROP TABLES

Small Cabinet: 024-036

STATIC	CFM												
	500	600	700	800	900	1000	1100	1200	1300	1400	1500	1600	
5 Kw	0.00	0.00	0.00	0.00	0.00	0.00	0.00	0.00	0.02	0.04	0.06	0.07	
7.5 Kw	0.00	0.00	0.00	0.00	0.00	0.00	0.02	0.03	0.05	0.07	0.08	0.09	
10 Kw	0.00	0.00	0.00	0.00	0.00	0.02	0.04	0.06	0.07	0.09	0.10	0.11	
15 Kw	0.00	0.00	0.00	0.02	0.04	0.06	0.08	0.10	0.12	0.14	0.16	0.18	

Large Cabinet: 042-060

STATIC	CFM														
	1100	1200	1300	1400	1500	1600	1700	1800	1900	2000	2100	2200	2300	2400	2500
5 Kw	0.00	0.00	0.00	0.01	0.02	0.03	0.04	0.05	0.06	0.07	0.08	0.09	0.10	0.11	0.12
7.5 Kw	0.00	0.00	0.01	0.02	0.03	0.04	0.05	0.06	0.07	0.08	0.09	0.10	0.11	0.12	0.13
10 Kw	0.00	0.00	0.01	0.02	0.03	0.04	0.05	0.06	0.07	0.08	0.09	0.10	0.11	0.12	0.13
15 Kw	0.00	0.02	0.03	0.04	0.05	0.06	0.07	0.08	0.09	0.10	0.11	0.12	0.13	0.14	0.15
20 Kw	0.02	0.03	0.04	0.05	0.06	0.07	0.08	0.09	0.10	0.11	0.12	0.13	0.14	0.15	0.16

WET COIL DELIVERY—STANDARD 50GL UNIT 024-060

230 AND 460 VOLT

Unit 50GL	Motor Speed		External Static Pressure (in.wg)										
			0.0	0.1	0.2	0.3	0.4	0.5	0.6	0.7	0.8	0.9	1.0
024	Low	Watts	281	282	281	278	276	—	—	—	—	—	—
		Cfm	833	776	702	638	554						
	Med	Watts	—	—	—	375	370	363	357	352	—	—	—
		Cfm	—	—	—	894	800	754	636	518	—	—	—
	High	Watts	—	—	—	—	—	468	457	444	431	423	—
		Cfm	—	—	—	—	—	884	802	697	467	397	—
030	Low	Watts	246	244	243	241	—	—	—	—	—	—	—
		Cfm	910	806	749	680	—	—	—	—	—	—	—
	Med	Watts	343	339	336	332	328	322	317	—	—	—	—
		Cfm	1148	1104	1028	958	850	782	645	—	—	—	—
	High	Watts	—	—	—	—	441	432	421	410	400	—	—
		Cfm	—	—	—	—	1102	988	896	783	529	—	—
036	Low	Watts	—	470	458	445	430	415	399	384	—	—	—
		Cfm	—	1350	1257	1240	1199	1107	1015	924	—	—	—
	Med	Watts	—	—	514	501	487	471	455	438	422	—	—
		Cfm	—	—	1338	1295	1288	1181	1111	968	813	—	—
	High	Watts	—	—	—	646	636	626	614	602	589	—	—
		Cfm	—	—	—	1385	1268	1196	1159	1032	948	—	—
042	Low	Watts	—	625	614	605	593	574	549	518	485	454	—
		Cfm	—	1540	1510	1473	1396	1348	1288	1192	1124	1037	—
	Med	Watts	—	—	—	—	726	695	661	625	591	561	540
		Cfm	—	—	—	—	1648	1593	1530	1446	1352	1237	1114
	High	Watts	—	—	—	—	—	—	—	790	766	742	713
		Cfm	—	—	—	—	—	—	—	1616	1492	1394	1283
048	Low	Watts	—	588	577	572	566	556	539	517	491	—	—
		Cfm	—	1514	1543	1467	1408	1374	1324	1237	1161	—	—
	Med	Watts	—	756	738	719	699	676	650	623	596	572	555
		Cfm	—	1785	1765	1706	1628	1577	1503	1421	1357	1298	1253
	High	Watts	—	—	—	—	896	862	829	800	775	752	728
		Cfm	—	—	—	—	1880	1804	1704	1547	1565	1406	1367
060	Low	Watts	903	898	873	842	814	792	777	764	743	701	618
		Cfm	2190	2158	2081	2026	1958	1866	1822	1744	1678	1535	1377
	Med	Watts	—	1002	978	960	941	914	880	839	798	764	750
		Cfm	—	2389	2291	2216	2120	2020	1952	1852	1727	1617	1549
	High	Watts	—	—	—	1080	1080	1066	1041	1008	972	938	—
		Cfm	—	—	—	2316	2181	2122	2101	2000	1802	1672	—

NOTES:

1. Deduct 10% For 208v.
2. Deduct field-supplied air filter pressure drop to obtain external Static pressure available for ducting.
3. Air delivery values are without air filter.
4. Dashes indicate portions of table that are beyond the blower motor capacity or are not recommended.

Electrical data

UNIT SIZE 50GL	V-PH-Hz	VOLTAGE RANGE		COMPRESSOR		OUTDOOR FAN MOTOR	INDOOR FAN MOTOR	ELECTRIC HEAT		POWER SUPPLY		
		Min	Max	RLA	LRA	FLA	FLA	Nominal kW*	FLA	UNIT MCA	MAX FUSE or CKT. BKR.	MOCP
024	208/230-1-60	187	253	13.5	61.0	0.8	2.0	—/—	—/—	19.7/19.7	25/25	—
								3.8/5.0	18.1/20.8	25.1/28.5	25/30	—
								5.4/7.2	25.9/30.0	34.9/40.0	40/50	—
030	208/230-1-60	187	253	14.7	73.0	0.8	2.1	7.5/10.0	36.1/41.7	47.6/54.6	50/60	—
								—/—	—/—	21.3/21.3	25/25	—
								3.8/5.0	18.1/20.8	25.2/28.7	25/30	—
	208/230-3-60	187	253	9.6	63.0	0.8	2.1	5.4/7.2	25.9/30.0	35.0/40.1	40/50	—
								7.5/10.0	36.1/41.7	47.8/54.7	50/60	—
								—/—	—/—	14.9/14.9	20/20	—
036	208/230-1-60	187	253	15.4	83.0	0.8	3.6	3.8/5.0	18.1/20.8	27.1/30.5	30/30	—
								5.4/7.2	25.9/30.0	36.9/42.0	40/50	—
								7.5/10.0	36.1/41.7	49.6/56.6	50/60	—
	208/230-3-60	187	253	12.2	77.0	0.8	3.6	11.3/15.0	54.2/62.5	72.2/82.6	—	80/90
								—/—	—/—	19.7/19.7	25/25	—
								3.8/5.0	10.4/12.0	15.7/17.7	20/20	—
	460-3-60	414	506	5.1	35.0	0.8	1.9	7.5/10.0	20.8/24.1	28.7/32.7	30/35	—
								11.3/15.0	31.3/36.1	43.6/49.6	45/50	—
								—/—	—/—	9.1	15	—
042	208/230-1-60	187	253	18.6	105.0	0.8	4.1	5.0	6.0	9.9	15	—
								10.0	12.0	17.4	20	—
								15.0	18.0	24.9	25	—
	208/230-3-60	187	253	13.8	88.0	0.8	4.1	—/—	—/—	28.2/28.2	35/35	—
								3.8/5.0	18.1/20.8	28.2/31.2	35/35	—
								5.4/7.2	25.9/30.0	37.5/42.6	40/50	—
	460-3-60	414	506	6.3	39.0	0.8	2.0	7.5/10.0	36.1/41.7	50.3/57.2	60/60	—
								11.3/15.0	54.2/62.5	72.8/83.3	—	80/90
								15.0/20.0	72.2/83.3	95.4/109.3	—	100/110
048	208/230-1-60	187	253	20.5	109.0	1.6	4.1	—/—	—/—	22.2/22.2	30/30	—
								3.8/5.0	18.1/20.8	22.2/22.2	30/30	—
								5.4/7.2	25.9/30.0	31.2/35.2	35/40	—
	208/230-3-60	187	253	14.7	91.0	1.6	4.1	7.5/10.0	20.8/24.1	30.6/34.6	35/35	—
								11.3/15.0	31.3/36.1	43.6/49.6	45/50	—
								15.0/20.0	41.6/48	57.1/65.1	—	60/70
	460-3-60	414	506	6.5	46.0	0.9	2.0	—/—	—/—	9.1	15	—
								5.0	6.0	10.7	15	—
								10.0	12.0	17.5	20	—
060	208/230-1-60	187	253	27.6	158.0	1.6	6.2	15.0	18.0	25.1	30	—
								20.0	24.1	32.6	35	—
								—/—	—/—	31.3/31.3	40/40	—
	208/230-3-60	187	253	18.1	137.0	1.6	6.2	3.8/5.0	18.1/20.8	31.3/31.3	40/40	—
								5.4/7.2	25.9/30.0	37.5/42.6	40/50	—
								7.5/10.0	36.1/41.7	50.3/57.2	60/60	—
	460-3-60	414	506	9.0	62.0	0.9	3.2	11.3/15.0	54.2/62.5	72.8/83.3	—	80/90
								15.0/20.0	72.2/83.3	95.4/109.3	—	100/110
								—/—	—/—	24.1/24.1	30/30	—
208/230-1-60	187	253	27.6	158.0	1.6	6.2	3.8/5.0	18.1/20.8	42.3/42.3	50/50	—	
							5.4/7.2	25.9/30.0	40.1/42.6	40/50	—	
							7.5/10.0	36.1/41.7	52.9/59.8	60/60	—	
208/230-3-60	187	253	18.1	137.0	1.6	6.2	11.3/15.0	54.2/62.5	75.4/85.9	—	80/90	
							15.0/20.0	72.2/83.3	98.0/111.9	—	100/125	
							—/—	—/—	30.4/30.4	35/35	—	
460-3-60	414	506	9.0	62.0	0.9	3.2	3.8/5.0	10.4/12.0	30.4/30.4	35/35	—	
							7.5/10.0	20.8/24.1	33.8/37.8	35/40	—	
							11.3/15.0	31.3/36.1	46.8/52.9	50/60	—	
460-3-60	414	506	9.0	62.0	0.9	3.2	15.0/20.0	41.6/48	59.7/67.7	—	60/70	
							—/—	—/—	15.4	20	—	
							5.0	6.0	15.4	20	—	
460-3-60	414	506	9.0	62.0	0.9	3.2	10.0	12.0	19.0	20	—	
							15.0	18.0	26.6	30	—	
							20.0	24.1	34.1	35	—	